



Global Systems & Technologies

GST, a company of values

GST is an Italian company that designs and directly manufactures welders and welding protection systems for the production of 3-piece metallic bodies of any size and for each type of line.

On the one hand the small size of the company favors flexibility, streamlined production, and direct communication with customers. On the other hand the technical know-how and the managerial capabilities are enhanced due to the multinational companies with whom we often collaborate. The company code and directives of GST impose high quality standards, reduced costs and tightly controlled timing in order to offer added value to our products. The care we devote to our customers during the design, production, installation and after-sales distinguish us for integrity and technical competence. Thanks to establishing and respecting these guidelines, GST has found an important place in the increasingly demanding metal packaging industry.



Strong roots in tradition, a natural orientation towards innovation

GST was founded in Italy by Emilio Mussino in 2000. Mussino began his career as a service engineer, and after many years of experience within the metal packaging industry, eventually progressed to become the founder of various companies manufacturing and supplying technical and innovative equipment to the metal packaging industry. In 2015 GST became part of a project in an enterprise network alongside OTS Assembly. This was coordinated in order to enhance innovative capacity, economic and technological development and competitiveness. This also optimized the means of access to both the national and international markets, purchasing, operating structures and the sharing of technical and informatic equipment.

GST's staff is composed of skilled workers who have worked for many years in this specific field and who are able to guarantee expertise and advanced know-how.

GST activity relates mainly to equipment intended for manufacturers of metal packaging. In addition, thanks to extensive knowledge of mechanics and resistance welding, GST is a reliable partner for the realization of special machines in different fields of application (automotive, household appliances, etc.) In fact, GST collaborates with major Italian and international companies offering support and expertise in providing turnkey lines for industrial leaders in this field.

GST provides a full range of service to its customers, taking care of all aspects from the machine concept down to the final installation and start-up. This is followed by a dynamic after-sales department which is staffed by highly skilled field engineers. GST also offers a punctual spare parts service.



One concept, many applications

The production facilities that are designed, manufactured and supplied directly from GST (“turnkey”) make use of roll forming and welding lines with which it is possible to realize a very wide range of products.

From 3-piece metal packaging to steel drums and cans, up to large drums up to 200 liters: the machinery designed and manufactured by GST is able to create water heaters and boilers, cans and pails, as well as products in square and rectangular body shape and aerosol cans in various sizes.



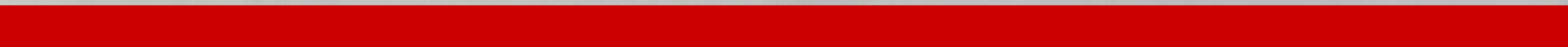

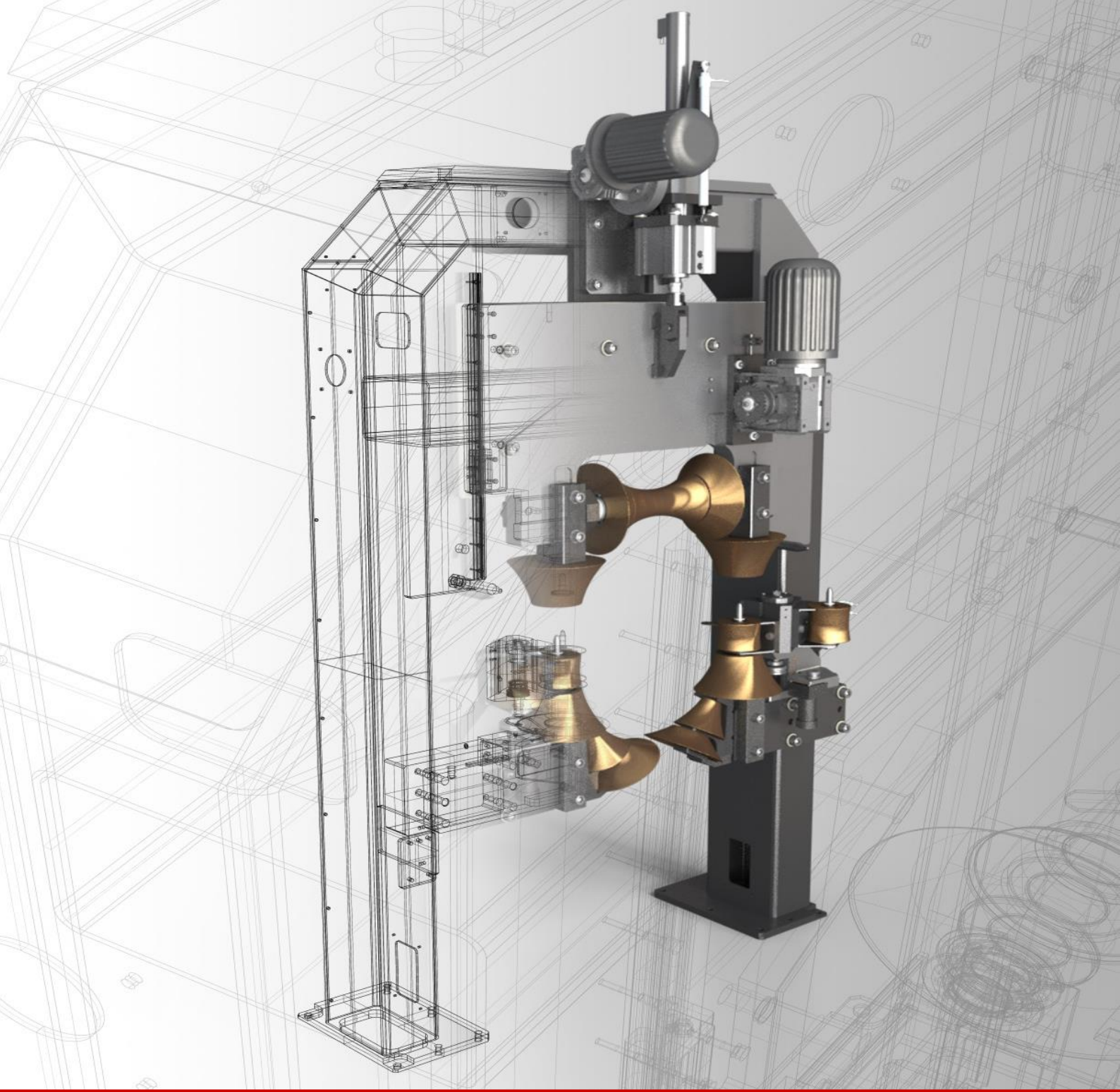

Design and assembly of equipment for every need

GST develops, designs, assembles and tests all of its machinery, entrusting specialized companies with the construction and provision of details and components. Our program includes many products belonging to two main categories:

ROLLER WELDING LINES

- Semi automatic and fully automatic steel drums welders, water heater welders
- Fully automatic tinplate cans and pails welders
- Special automatic roll forming / welding machines for square, rectangular or other shaped metal containers
- Automatic sheet feeder and destaker from bundles or from coil cutting lines.

SIDE STRIPE PROTECTION SYSTEMS

- Automatic and semi-automatic electrostatic powder seam coating systems for cans, aerosol cans, pails and drums
- Lacquer application for inside and outside protection of welded seam coating on cans, aerosol cans, as well as on drums
- Linear and U-shape gas or electric curing system for cans, aerosol cans, pails and drums
- Lacquer application systems for welded ear protection on pails.

Appliance Sector - Conveyors and magnetic elevators for cans and drums (water heaters, dishwashers, etc.)

Automotive Sector - GST offers its expertise and technology to design and produce other types of special machines in the application fields of welding resistance and mechanics in the automotive sector (component assembly systems, Testers, etc.)

Seam welders for drums and water heaters

Automatic resistance seam welders for drums, pails, water heater tanks and jackets as well as for other medium to large size bodies in steel and stainless steel. Special machine configuration, which incorporates a fully automatic and fast tool change-over system, with the possibility to weld shaped bodies (square, rectangular, etc.). Power consumption is reduced considerably with the aid of the latest generation of electronic welding controls.

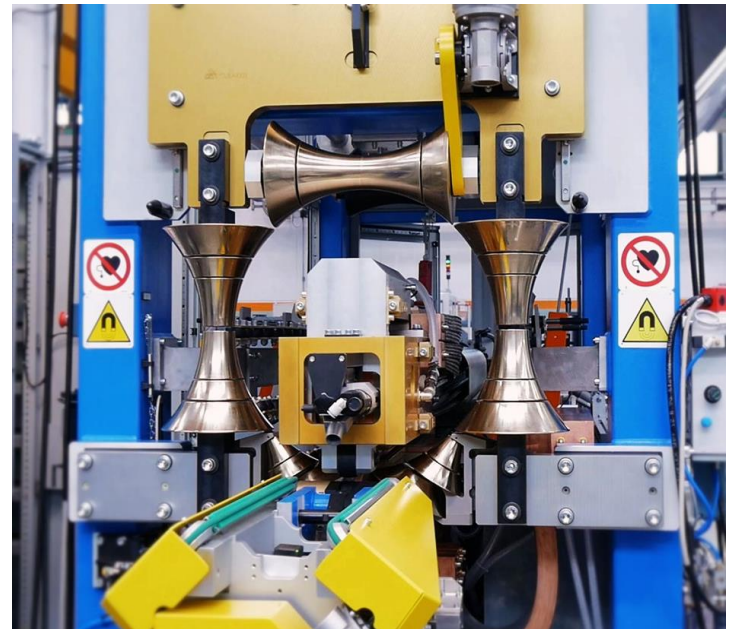

Can body welders

Automatic resistance welding bodymakers for the production of cans, pails, small drums and other metal packaging containers in black steel, tinfoil and other coated materials for both food and general line industries. Simple and fast tool change-over, easy adjustment, process control via a touch screen panel, all of which makes these machines a flexible and economical production tool

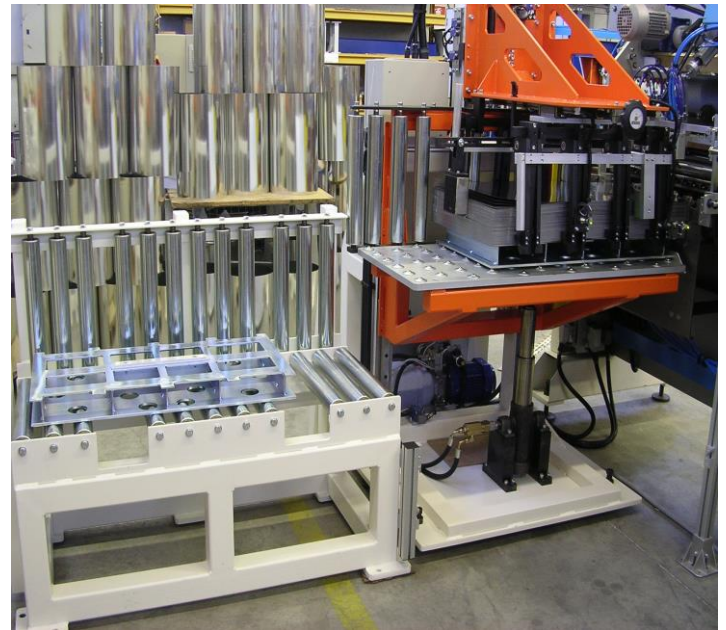
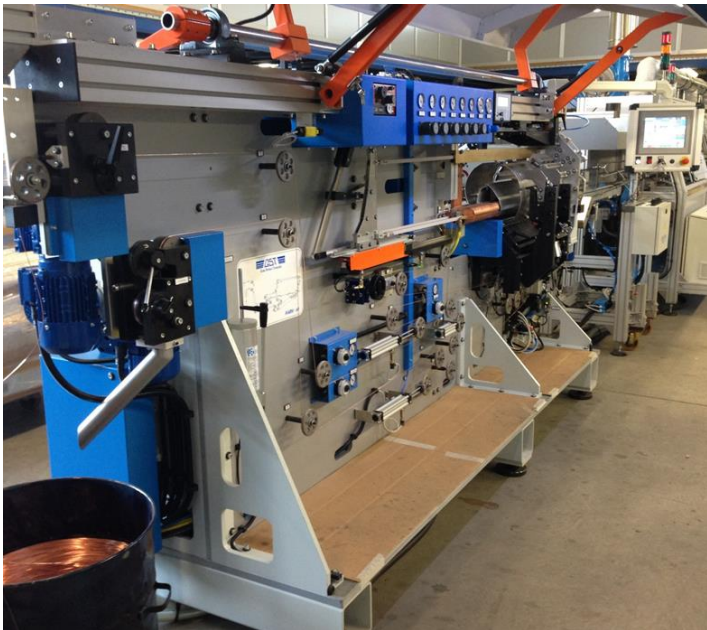

NO-STOP feeder

Second generation of our special no-stop metal sheets feeder.

This new feeder version, picking from two separate metal sheets elevators (option), could operate without any loading cycle stop.

The presence of lights curtains, allows a loading operation in safety conditions while the machine is working.

The double elevator system reduces the picking time, approaching the metal sheets stack to the sucking cups.

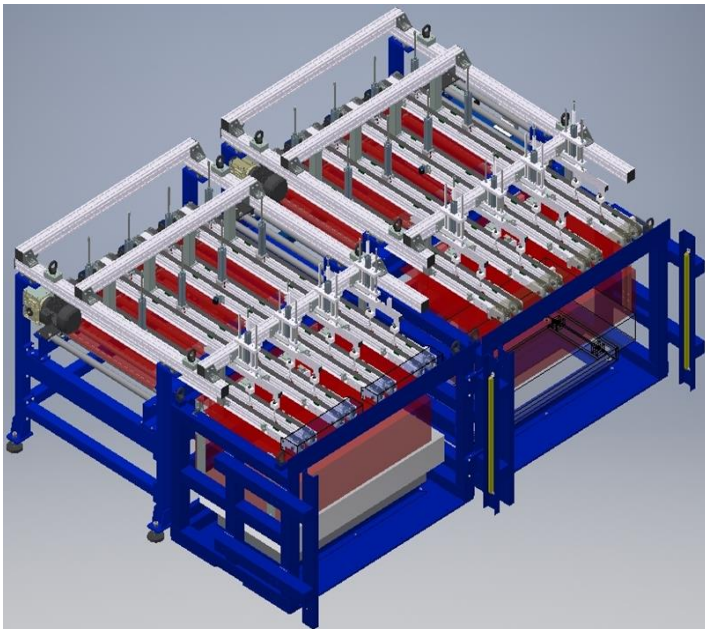

Semi-automatic welding machine

The S.M.B 120 GST semiautomatic welding machine is a reliable, versatile and extremely flexible machine; it is possible to achieve high productions by reducing batch change times to a minimum.

With a quick and simple change of tooling, it is possible produce a wide of products, from 220 mm pails up to 571.5 mm drums.

The front loading and downloading operation is easy, safe and ergonomic.

Z-bar and hourglass rolls calibration crown are engineered for a precise overlap control and for a top quality process.

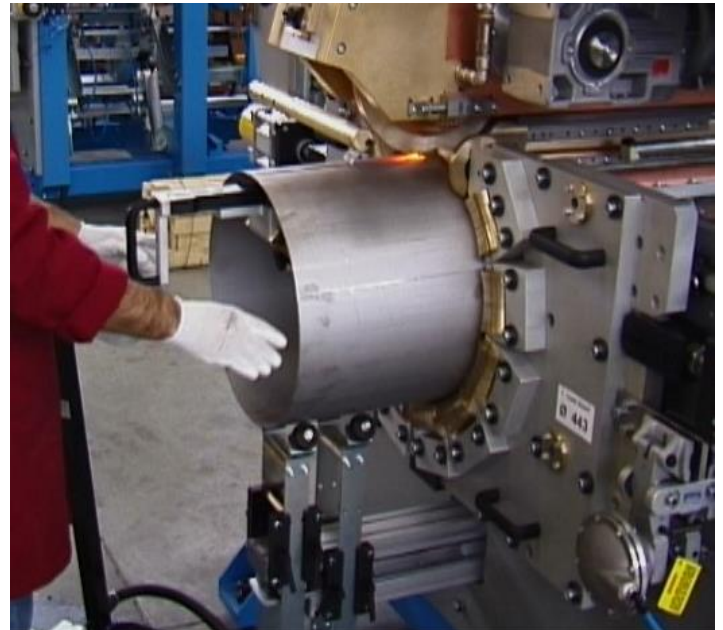
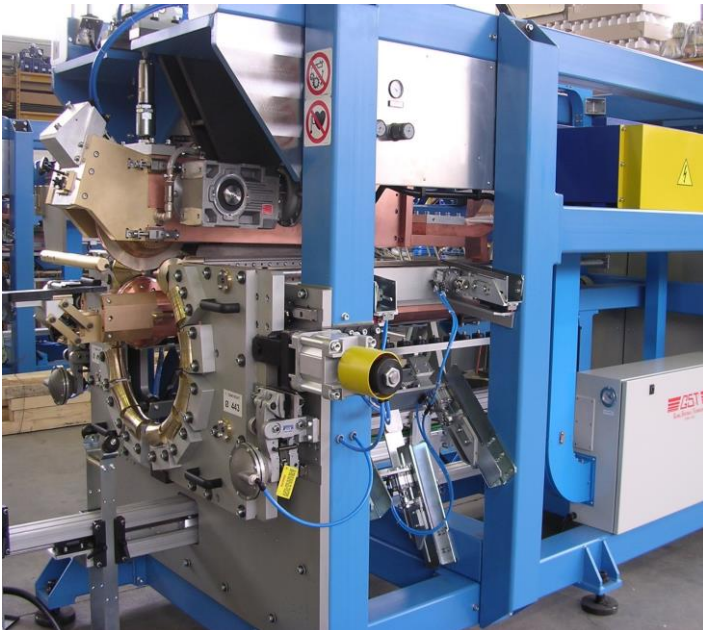

Seam powder coating

Automatic electrostatic powder coating system designed for the protection of welded seams on a large size range of metal containers. This system can be supplied to work on a single production line or on two lines simultaneously.

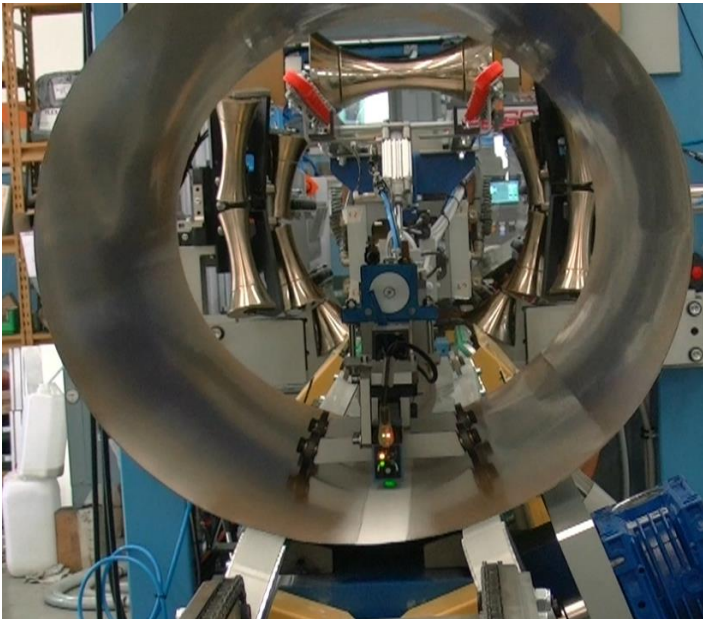

Seam curing systems

Modular curing systems for the polymerization of seam protection powder and lacquer on all types of metal containers and suitable for any production capacity. The curing systems, powered by gas or electricity, can be supplied either straight or U-shaped depending on customer requirements.

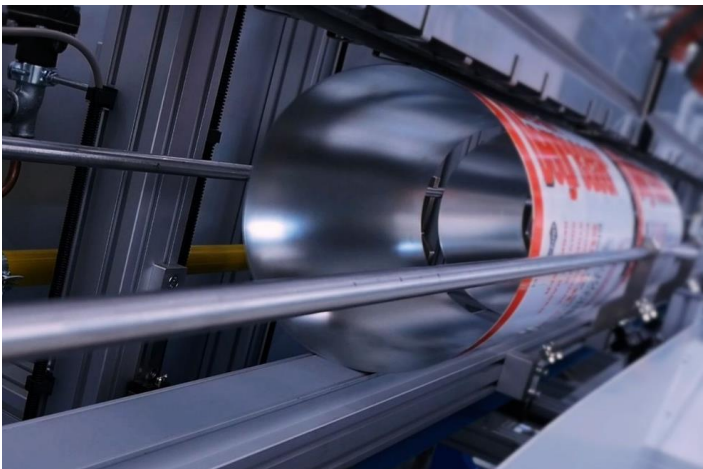

Seam lacquer coating

Automatic lacquer application systems for the protection of internal and external welded seams on a wide variety of metal containers. Lacquer is applied by either roller, brush, spray or airless spray systems to meet the quality specifications and performance required

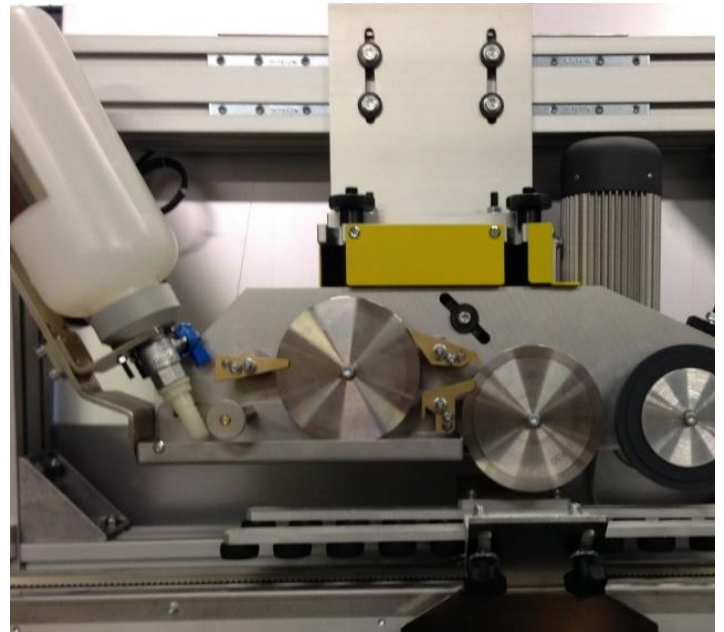

After sales

Spare parts:

GST is able to assist in finding the spare parts, many of which are always available in stock, both for recently built and older systems. Some of these: welding mandrel, Z-Bar, ...

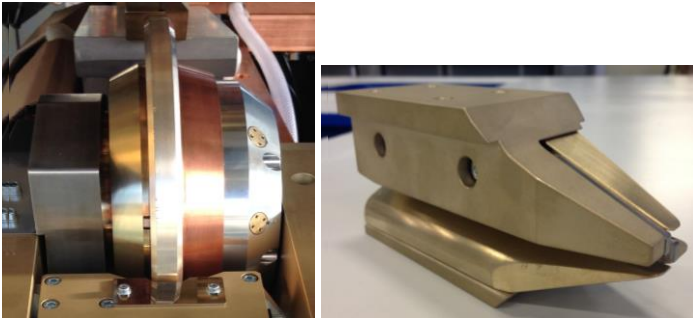

Revisions:

Thanks to the internal GST is also involved in the revision and upgrade of equipment such as welding machines, curing systems, powder coating systems and other installations related to the production lines of cans, pails and drums.



GST, a local reality with a global vision



GS&T Global Systems & Technologies S.r.l.

Via Massimo D'Antona, 1/11 - fraz. Pasta
Rivalta di Torino (TO) 10040 Italy

T +39 011 9665880 F +39 011 9665888
E info@gstmachinery.it - W www.gstmachinery.com