



COATING SYSTEM → FOCUS ON LAQUER SYSTEMS



Complete range int. and ext. drum/can protection

1. Airless wet lacquer application system

2. Airspray wet lacquer application system

3. Roller coating

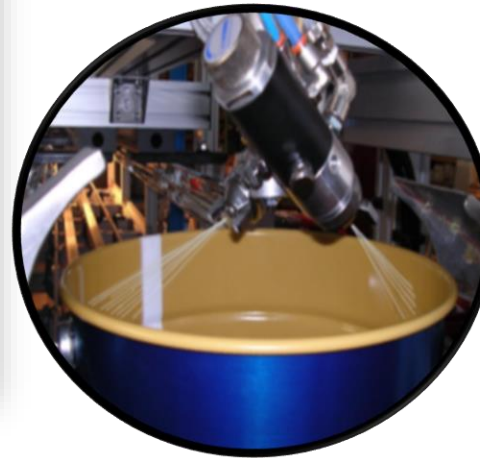

EARS PROTECTION ON PAILS:
Automatic wet lacquer spray systems for the protection of welded ears on pails



Stand-alone system





Over spray sucking system

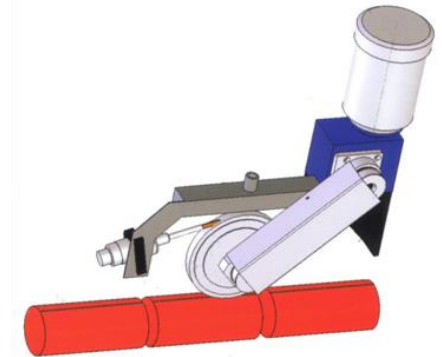

Can be integrated on all existing line (welding with all diameters) and for high cadence machinery

BOTTOM ROLLER SEAM PROTECTION:
Wet lacquer roller application system for new production lines or to retrofit existing operation with bottom welded cans

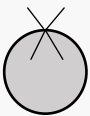

DESCRIPTION	PARAMETER	AIR LESS	AIR SPRAY	ROLLER
Body size	∅ mm	45 - 600	45 - 600	45 - 160
Production speed	mt/ 1'	6 - 120	6 - 45	6 - 70
Welded seam position		Top/bottom	Top/bottom	Top/bottom
Protection side		Inside/outside	Inside/outside	Outside